

2d

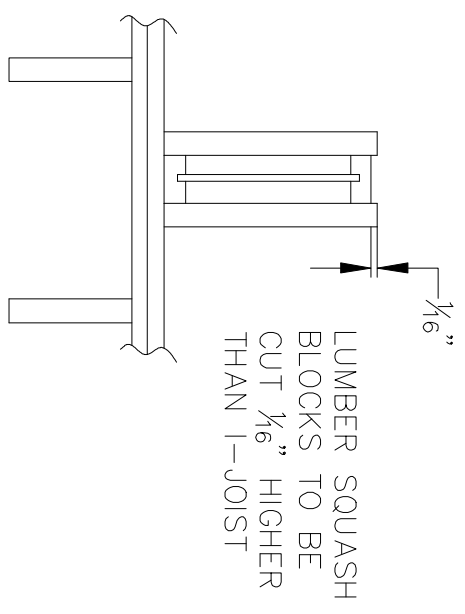
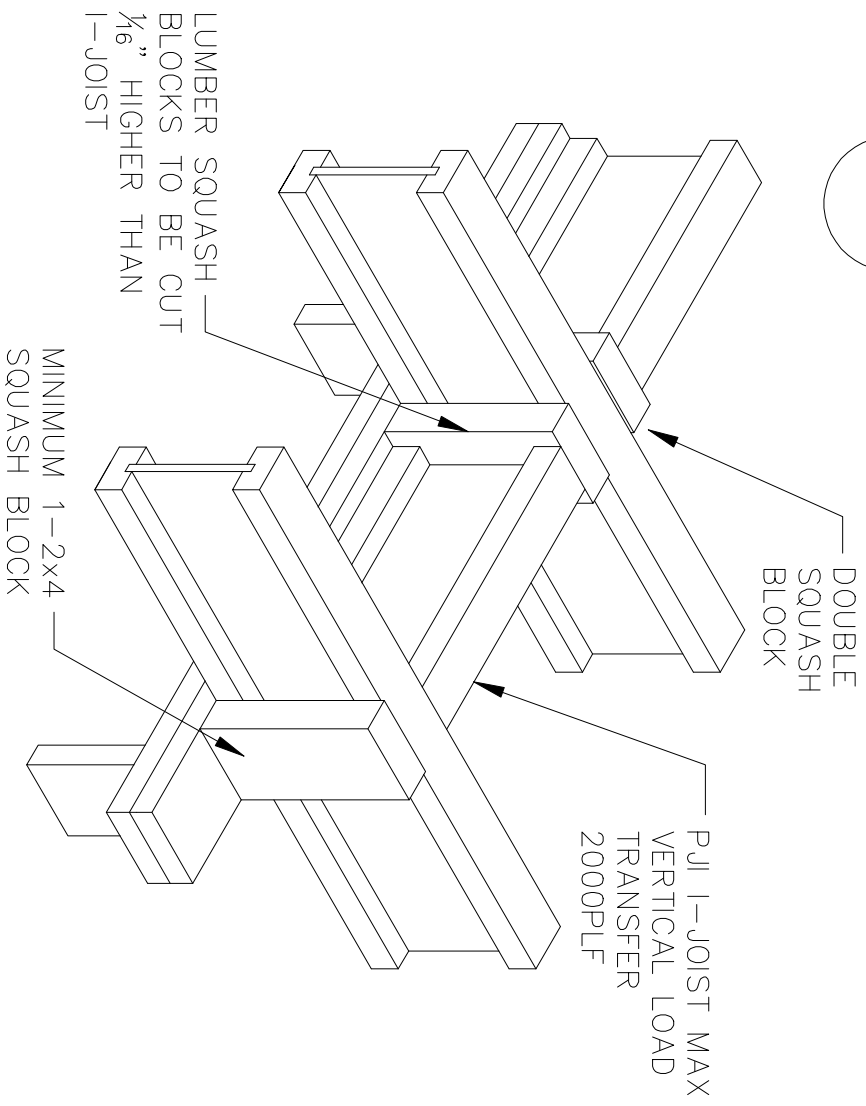

SQUASH BLOCK	(lb)
1" x 3 1/2" APA RIM*	1900
1" x 5 1/2" APA RIM*	3000
1 1/8" x 3 1/2" APA RIM*	2600
1 1/8" x 5 1/2" APA RIM*	4000
1-2x4	1900
1-2x6	2800
2-2x4	3800
2-2x6	5900

PROVIDE LATER BRACING AS PER DETAIL 2a, 2b & 2c